

Manifold Fittings

Standard and High-Pressure Fittings

Features & Benefits:

- Designed to withstand the fast and full flow applications
- Designed for erosion free operations
- An optimization for minimum weight
- Designed with Butt-Weld End connections
- Used in application such as cement manifold and standpipe manifold
- An integral bull-plug or top outlet connections available with the fittings
- Minimum Yield is 75K for the high-pressure fittings
- Weld schedule shall be XXS for pressure more than 5K and schedule 80 for 2K and 3K
- Manufacturing to the highest quality standards in the industry

Technical Specification:	
Fitting Sizes	2" to 7"
API Pressure Rating (PSI)	2000 PSI - 10000 PSI
Material Form	Cast (ASTM A487 Gr 4)
Material Class	EE or Higher
Temperature Class	-20°F to +250°F
Connections	Butt-Weld, Flanged, Hub ends, Union Ends
Service Condition	NACE MR0175 / H2S Service
Material Strength	Yield Strength 75K and above
Standards	ANSI B31.3, ASME B36.1, API 6A, ASME B16.9, MSS-SP-75



90° Long Sweep Elbow:									
Size	A	B	BW Schedule XXS			BW Schedule 160			
			C	D	Weight (Kgs)	C	D	Weight (Kgs)	
2"	8.00	8.00	1.50	2.37	15	1.69	2.37	12	
3"	8.00	8.00	2.30	3.50	23	2.62	3.50	21	
4"	11.00	11.00	3.15	4.50	40	3.44	4.50	42	
5"	12.00	12.00	4.06	5.56	58	4.31	5.56	54	
6"	15.00	15.00	4.90	6.62	96	5.19	6.62	90	
7"	11.88	11.88	5.13	7.00	63	-	-	-	

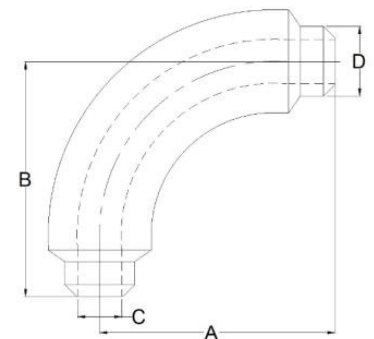

45° Long Sweep Elbow:								
			BW Schedule XXS			BW Schedule 160		
Size	A	B	C	D	Weight (Kgs)	C	D	Weight (Kgs)
2"	4.65	4.65	1.50	2.37	10	1.69	2.37	8
3"	4.65	4.65	2.30	3.50	14	2.62	3.50	13
4"	6.38	6.38	3.15	4.50	29	3.44	4.50	28
5"	6.73	6.73	4.06	5.56	38	4.31	5.56	36
6"	8.00	8.00	4.90	6.62	73	5.19	6.62	71
7"	6.61	6.61	5.13	7.00	42	-	-	-

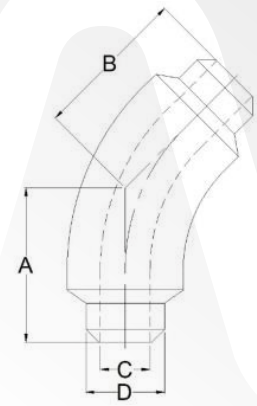

Long Sweep Tee								
			BW Schedule XXS			BW Schedule 160		
Size	A	B	C	D	Weight (Kgs)	C	D	Weight (Kgs)
2"	13.00	8.00	4.50	5.91	1.50	2.37	38.00	1.69
3"	13.00	8.00	4.50	5.91	2.30	3.50	32.00	2.62
4"	16.00	11.00	5.50	8.27	3.15	4.50	53.00	3.44
5"	19.00	12.00	6.60	9.45	4.06	5.56	75.00	4.31
6"	27.00	15.00	7.75	12.00	4.90	6.62	140.00	5.19
7"	18.74	11.89	8.25	9.00	5.13	7.00	99.00	-

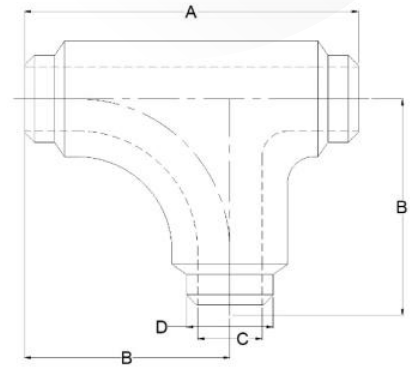

Full Flow Tee								
			BW Schedule XXS			BW Schedule 160		
Size	A	B	C	D	Weight (Kgs)	C	D	Weight (Kgs)
2"	16.00	8.00	4.50	5.91	1.50	2.37	45.00	1.69
3"	16.00	8.00	4.50	5.91	2.30	3.50	40.00	2.62
4"	22.00	11.00	5.50	8.27	3.15	4.50	64.00	3.44
5"	24.00	12.00	6.60	9.45	4.06	5.56	89.00	4.31
6"	30.00	15.00	7.75	12.00	4.90	6.62	171.00	5.19
7"	23.78	11.89	8.25	9.00	7.00	5.13	106.00	-

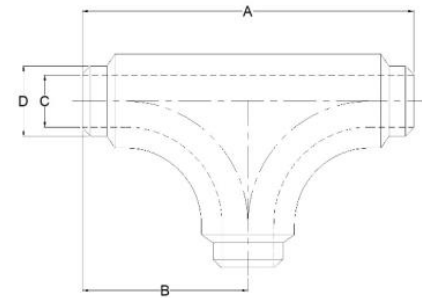

Full Flow Cross								
			BW Schedule XXS			BW Schedule 160		
Size	A	B	C	D	Weight (Kgs)	C	D	Weight (Kgs)
2"	16.00	8.00	4.50	5.91	1.50	2.37	58	1.69
3"	16.00	8.00	4.50	5.91	2.30	3.50	61	2.62
4"	22.00	11.00	5.50	8.27	3.15	4.50	82	3.44
5"	24.00	12.00	6.60	9.45	4.06	5.56	112	4.31
6"	30.00	15.00	7.75	12.00	4.90	6.62	245	5.19

