

Model S200

Manual Gate Valve

SAYATVA'S Model S200 is similar to FLS style & field-proven valve that offers various features making it suitable for drilling and production applications in oil and gas services up to 15,000 PSI operating pressure.

Reliability:

The **Model S200** valve has a track record of proven performance in the field, indicating its reliability.

Bi-directional Sealing:

The valve is designed to provide sealing in both directions, ensuring effective isolation. This feature is particularly beneficial in applications where flow reversal may occur or when the valve needs to block fluid in either direction.

Body without Penetrations:

The valve body has no penetrations. Grease injection fitting is located on the bonnet, on the downstream side of the backseat for safety.

Stem Packing Design:

Stem seal design covers a wide range of pressures, temperatures, and fluids encountered in wellhead and manifold service.

Application:

- Drilling Application
- Production Applications
- Well Head & Christmas Tree equipment
- Choke & Kill manifold
- MPD Manifolds
- Mud applications



Features & Benefits:

- Bi-directional valve
- Single Seat Design
- Floating Slab gate Design for better sealing
- Back seat as standard to meet API 6A requirement
- True low-pressure sealing
- Metal to metal sealing provides extended service life between maintenance periods
- No elastomers used for sealing
- Designed for extreme pressure and temperature
- Downstream sealing with reductant seal
- Various trims are available to meet different operating conditions
- Valve opens and closes without requiring excessive torque
- Bearing cap grease fitting allows positive bearing lubrication
- Easy Assembly and Disassembly
- Low Maintenance

Model S200

Manual Gate Valve

Technical Specification:	
Inlet / Outlet Connections	2-1/16" to 7-1/16"
API Pressure Rating (PSI)	2000, 3000, 5000, 10000, 15000
Design Standard	API Spec 6A Latest Edition
Material Class	API Material class DD up to HH-NL - The valve body / bonnet with forged construction - The valve body with cast construction as an option - API 75K material, impact tested
Temperature Range	-50 deg. F to 350 deg. F
PSL	PSL 1, PSL 2, PSL 3 & PSL 3G
PR	PR 1, PR 2, PR2F
Service Condition	NACE MR0175 / H2S Service.
Trim options	Single Seat design with Gates and Seats are Hard Faced to Tungsten Carbide (TC). Gate and Seat can be nitrided or QPQ as an Option.
Actuation	Manual Handwheel / Gear Operated Actuation
Bolting	As per API 20E Monogrammed (BSL 1, BSL 2, BSL 3)
Inlay Requirements	Alloy 625 inlay for ring grooves, seat pockets. Bonnet grooves (upon request)
Flange Face to Face Reference	As per API 6A latest Edition
Monograms	As per API 6A latest Edition
Certifications / Type Approval	Additional Third-party certification available upon request
Aramco Requirements	Valves in compliance with Aramco Well Control 6 th Edition are available upon request

Valve Dimensions:			
Valve Size	Face to Face (A) (±0.06)	Height (B) (±0.04)	Weight (lbs)
5000 PSI			
2-1/16"	14.62"	23.00"	175
3-1/8"	18.62"	26.45"	360
4-1/16"	21.62"	31.13"	545
7-1/16"	32.00"	43.56"	1700
10000 PSI			
2-1/16"	20.50"	23.25"	275
3-1/16"	24.38"	26.26"	680
4-1/16"	26.38"	32.00"	1100
7-1/16"	35.00"	70.54"	3000
15000 PSI			
2-1/16"	19.00"	21.92"	350
3-1/16"	23.56"	33.85"	1065
4-1/16"	29.00"	57.50"	1400

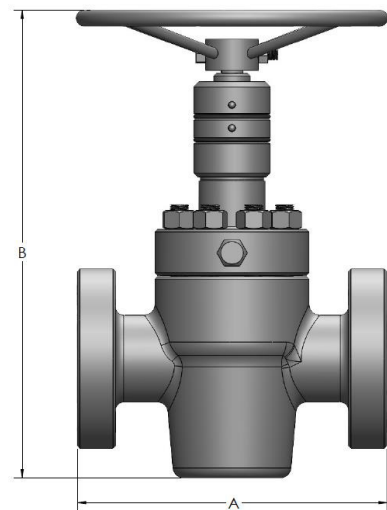

Other sizes dimension details are available upon request. For further questions or quotations requests, contact sales@sayatva.com.

Model S200

Manual Gate Valve

